

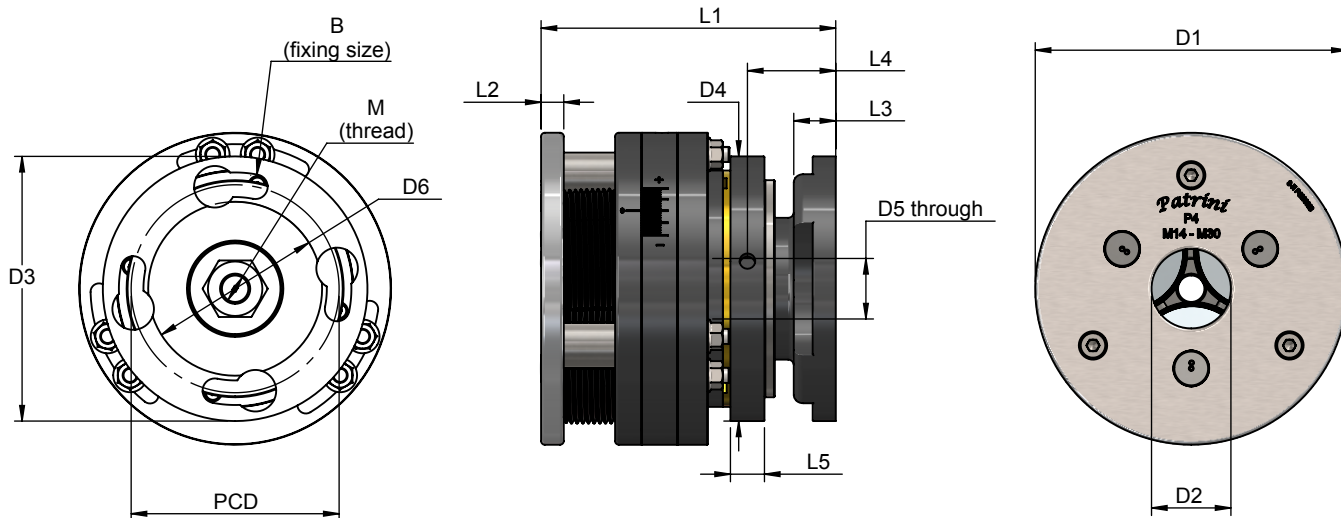

Patrini

Thread Rolling Equipment

www.patrini.net
 info@patrini.net
 0044 7970 119013
 0088 6910 509969

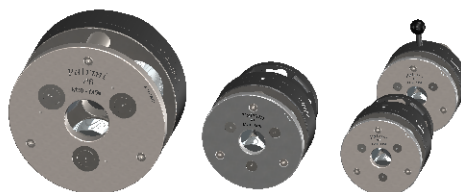

Head Type**	L1	L2	L3	L4	L5	D1	D2	D3	D4	D5	D6 (G7)	PCD	B	M	Threading Range	Weight (kg)
P4R*	156	12	22	47	18	165	42	140	140	32	92	110	M12	M16-LH	M14-M30	15
P4RF*	156	12	22	47	18	165	42	140	140	32	92	110	M12	M16-LH	M14-M30	15
P5R	190	12	25	57	22	200	53	200	158	40	140	170	M12	M18-LH	M18-M36	26
P5RF	190	12	25	57	22	200	53	200	158	40	140	170	M12	M18-LH	M18-M36	26
P6R	275	22	30	62	30	320	90	225	252	63	140	180	M16	M24-LH	M30-M56	76

*The P4R head has an optional Arbor Mount

**Rolling Heads with the additional designation 'F' are for fine pitch production (eg P5RF) - please see thread roll schedule for scope

All dimensions are given in millimetres unless otherwise stated